

HPW102, 103 series

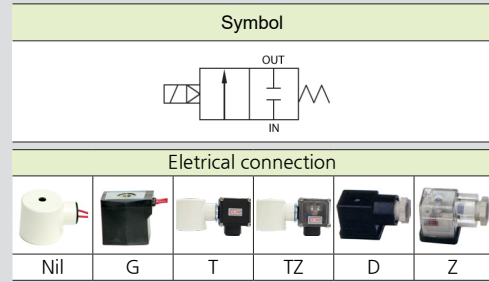

HPW 102
HPW 103



How to Order

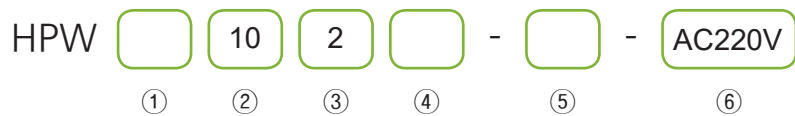

① Port type

Nil	Rc(PT) (Standard)
G	G

② Orifice

10	Ø10
----	-----

③ Port size

2	1/4
3	3/8

④ Electrical connection

Nil	Console box (Standard)
G	Grommet coil
T	Console box + Terminal box
TZ	Console box + Terminal box (Lamp)
D	DIN coil + DIN connector
Z	DIN coil + DIN connector (Lamp)

⑤ Seal material

	Material	Applications
Nil	NBR	Standard
M	FPM	Chemical, Hot water 120°C
SL	SILICONE	Clean water -5~60°C
E	EPDM	Hot water 100°C

⑥ Rated voltage

AC110V	AC110V 60Hz
AC220V	AC220V 60Hz
DC12V	DC12V
DC24V	DC24V
AC100V	AC100V 50/60Hz
AC200V	AC200V 50/60Hz
AC220V-50Hz	AC 220V 50Hz
AC240V-50Hz	AC 240V 50Hz
AC24V-50Hz	AC 24V 50Hz

Specifications

Classification	Standard	Option	Classification	Standard	Option	
Fluid	Air, Water, Clean oil, Inert gas		Voltage	AC100V 50/60Hz AC110V 60Hz AC200V 50/60Hz AC220V 60Hz DC24V, 12V	AC220V 50Hz AC240V 50Hz AC24V 50Hz	
Fluid temp.	0 ~ 60°C	EPDM(100°C) FPM(120°C)		Allowable voltage fluctuation	±10% (AC), ±5% (DC)	
Ambient temp.	50°C (Max.)				Power consumption	AC, DC : 14W
Pressure range	AC 0~10kgf/cm ² (0~1MPa)	Vacuum(10 ⁻³ Torr)	Body material	Brass		
	DC 0.1~7kgf/cm ² (0.01~0.7MPa)			Seal material	NBR	EPDM, FPM, SILICONE
Coil insulation	Class B		Weight		0.53Kg	
Electrical connection	Lead wire	Grommet coil Terminal box DIN connector				
Port size	Rc(PT) 1/4, 3/8					
Orifice	Ø10					

Features

- Diaphragm type
- Normally closed type
- Fire resistant structure, high durability
- Combines the strengths of pilot type and direct acting type
- Seal material can be changed depending on fluid specifications.

Applications

- Water piping
- Medical instrument
- Water purifier
- Vacuum packing machine
- Wire cutting machine

* Not available in explosive atmosphere.
* If oil is applied, the range of pressure shall be based on 50cst for oil viscosity.

Dimensions

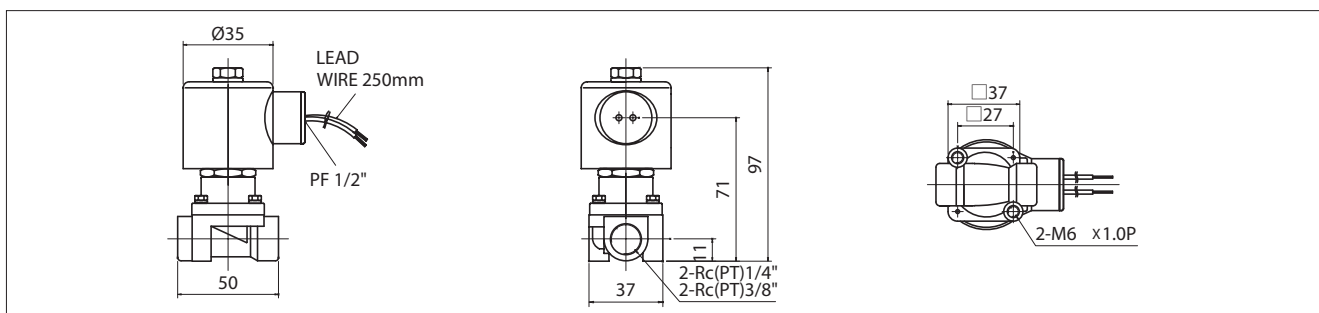

HPW154 series

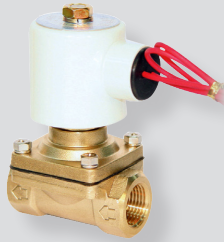

HPW 154

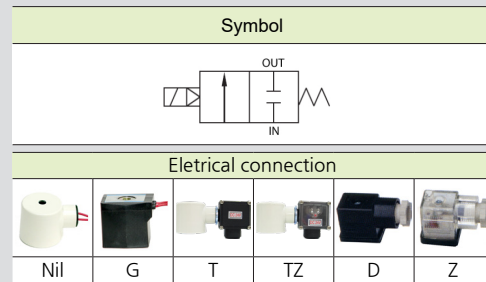

How to Order

HPW 15 4 - - AC220V

①

②

③

④

⑤

⑥

① Port type

Nil	Rc(PT) (Standard)
G	G

② Orifice

15	Ø15
----	-----

③ Port size

4	1/2
---	-----

④ Electrical connection

Nil	Console box (Standard)
G	Grommet coil
T	Console box + Terminal box
TZ	Console box + Terminal box (Lamp)
D	DIN coil + DIN connector
Z	DIN coil + DIN connector (Lamp)

⑤ Seal material

	Material	Applications
Nil	NBR	Standard
M	FPM	Chemical, Hot water 120°C
E	EPDM	Hot water 100°C

⑥ Rated voltage

AC110V	AC110V 60Hz
AC220V	AC220V 60Hz
DC12V	DC12V
DC24V	DC24V
AC100V	AC100V 50/60Hz
AC200V	AC200V 50/60Hz
AC220V-50Hz	AC 220V 50Hz
AC240V-50Hz	AC 240V 50Hz
AC24V-50Hz	AC 24V 50Hz

Specifications

Classification	Standard	Option	Classification	Standard	Option	
Fluid	Air, Water, Clean oil, Inert gas		Voltage	AC100V 50/60Hz AC110V 60Hz AC200V 50/60Hz AC220V 60Hz DC24V, 12V	AC110V 50Hz AC220V 50Hz AC240V 50Hz AC 24V 50Hz	
Fluid temp.	0 ~ 60°C	EPDM FPM		Allowable voltage fluctuation	±10% (AC), ±5% (DC)	
Ambient temp.	50°C (Max.)				Power consumption	DC : 14W
Pressure range	AC	0.1 ~ 10kgf/cm ² (0.01 ~ 1MPa)	Coil insulation	Class B		
	DC	0.1~7kgf/cm ² (0.01 ~ 0.7MPa)		DC:0.3~10kgf/cm ² (0.03 ~ 1MPa) Vacuum	Electrical connection	Lead wire
Body material	Brass			Seal material	NBR	EPDM, FPM
Port size	Rc(PT) 1/2			Weight	0.75Kg	
Orifice	Ø15					

Features

- Diaphragm type
- Normally closed type
- Combines the strengths of pilot type and direct acting type
- Seal material can be changed depending on fluid specifications.
- Fire resistant structure, high durability

Applications

- Water piping
- Boiler
- Water purifier
- Medical instrument
- Industrial cleaner

※ Not available in explosive atmosphere. ※ If oil is applied, the range of pressure shall be based on 50cst for oil viscosity.

Dimensions

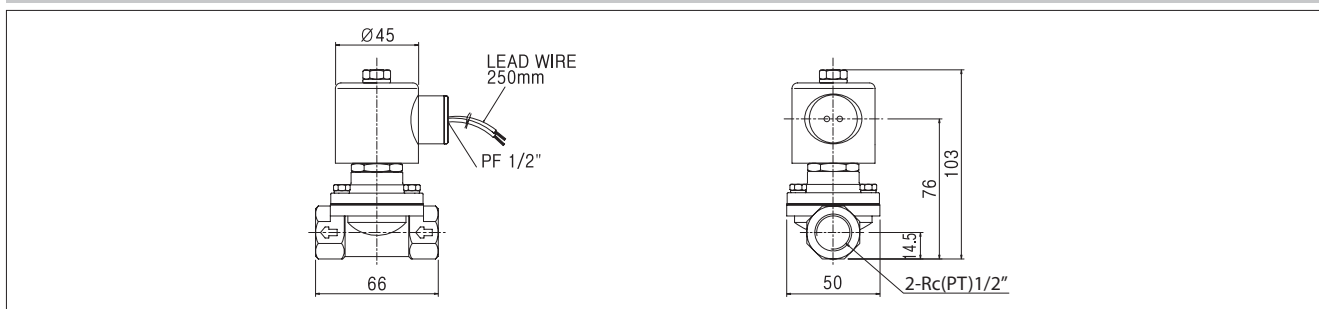

HPW206, 2510 series

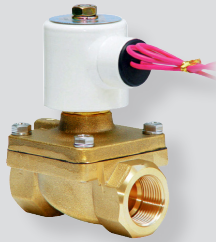

HPW 206

Symbol					
Electrical connection					
Nil	G	T	TZ	D	Z

How to Order

HPW 206 - - AC220V

① ② ③ ④ ⑤

① Port type

Nil	Rc(PT) (Standard)
G	G

② Orifice & Port size

	Orifice	Port size
206	Ø20	3/4
2510	Ø25	1

④ Electrical connection

Nil	Console box (Standard)
G	Grommet coil
T	Console box + Terminal box
TZ	Console box + Terminal box (Lamp)
D	DIN coil + DIN connector
Z	DIN coil + DIN connector (Lamp)

④ Seal material

	Material	Applications
Nil	NBR	Standard
M	FPM	Chemical, Hot water 120°C
E	EPDM	Hot water 100°C

⑥ Rated voltage

AC110V	AC110V 60Hz
AC220V	AC220V 60Hz
DC12V	DC12V
DC24V	DC24V
AC100V	AC100V 50/60Hz
AC200V	AC200V 50/60Hz
AC220V-50Hz	AC 220V 50Hz
AC240V-50Hz	AC 240V 50Hz
AC24V-50Hz	AC 24V 50Hz

Specifications

Classification	Standard	Option	Classification	Standard	Option
Fluid	Air, Water, Clean oil, Inert gas		Voltage	AC100V 50/60Hz AC110V 60Hz AC200V 50/60Hz AC220V 60Hz DC24V, 12V	AC110V 50Hz AC220V 50Hz AC240V 50Hz AC 24V 50Hz
Fluid temp.	0 ~ 60°C	EPDM (100°C) FPM (120°C)			
Ambient temp.	50°C (Max.)				
Pressure range	AC: 0~10kgf/cm ² (0~1MPa) DC: 0~7kgf/cm ² (0~0.7MPa)	Vacuum	Allowable voltage fluctuation	±10% (AC), ±5% (DC)	
Coil insulation	Class B		Power consumption	AC, DC : 14W	
Electrical connection	Lead wire G(PF)1/2	Grommet coil Terminal box DIN connector	Body material	Brass	
Port size	Rc(PT) 3/4, 1		Seal material	NBR	EPDM, FPM
Orifice	Ø20, Ø25		Weight	Refer to the table below	

Features

- Diaphragm type
- Normally closed type
- Combines the strengths of pilot type and direct acting type
- Seal material can be changed depending on fluid specifications.
- Fire resistant structure, high durability

Applications

- Water piping
- Medical instrument
- Boiler
- Air conditioner
- Water purifier
- Compressor

* Not available in explosive atmosphere. * If oil is applied, the range of pressure shall be based on 50cst for oil viscosity.

Dimensions

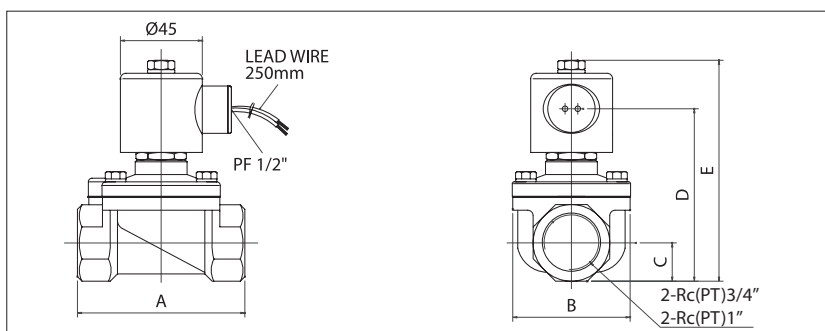

Model	A	B	C	D	E	Weight (kg)
HPW 206	92	65.5	18	88	114	1.2
HPW 2510	92	64.5	21	95	121	1.3

HPW3212, 4014, 5020 series



HPW 4014

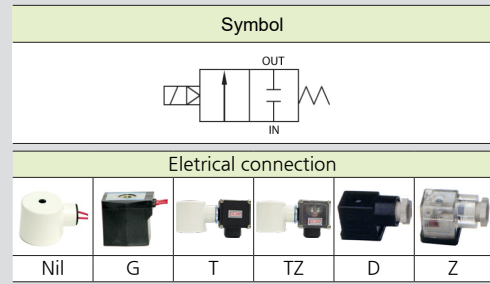

How to Order



① Port type

Nil	Rc(PT) (Standard)
G	G

② Orifice & Port size

	Orifice	Port size
3212	Ø32	1 1/4
4014	Ø40	1 1/2
5020	Ø50	2

④ Electrical connection

Nil	Console box (Standard)
G	Grommet coil
T	Console box + Terminal box
TZ	Console box + Terminal box (Lamp)
D	DIN coil + DIN connector
Z	DIN coil + DIN connector (Lamp)

④ Seal material

	Material	Applications
Nil	NBR	Standard
M	FPM	Chemical, Hot water 120°C
E	EPDM	Hot water 100°C

⑥ Rated voltage

AC110V	AC110V 60Hz
AC220V	AC220V 60Hz
DC12V	DC12V
DC24V	DC24V
AC100V	AC100V 50/60Hz
AC200V	AC200V 50/60Hz
AC220V-50Hz	AC 220V 50Hz
AC240V-50Hz	AC 240V 50Hz
AC24V-50Hz	AC 24V 50Hz

Specifications

Classification	Standard	Option	Classification	Standard	Option	
Fluid	Air, Water, Clean oil, Inert gas		Voltage	AC100V 50/60Hz AC110V 60Hz AC200V 50/60Hz AC220V 60Hz DC24V, 12V	AC220V 50Hz AC240V 50Hz AC 24V 50Hz	
Fluid temp.	0 ~ 60°C	EPDM(100°C) FPM(120°C)		Allowable voltage fluctuation	±10% (AC), ±5% (DC)	
Ambient temp.	50°C (Max.)				Power consumption	AC, DC : 14W
Pressure range	0.3 ~ 10kgf/cm ² (0.03 ~ 1MPa)		Body material	Brass		
Coil insulation	Class B		Seal material	NBR	EPDM, FPM	
Electrical connection	Lead wire G(PF)1/2	Grommet coil Terminal box DIN connector	Weight	Refer to the table below		
Port size	Rc(PT) 1 1/4, 1 1/2, 2					
Orifice	Ø32, Ø40, Ø50					

※ Not available in explosive atmosphere.

※ If oil is applied, the range of pressure shall be based on 50cst for oil viscosity.

Features

- Diaphragm type
- Normally closed type
- Designed to operate with low differential pressure of (0.3kgf/cm²)
- Seal material can be changed depending on fluid specifications.
- Fire resistant structure, high durability

Applications

- Water piping
- Industrial cleaner
- Ventilator
- Air conditioner
- Compressor

Dimensions

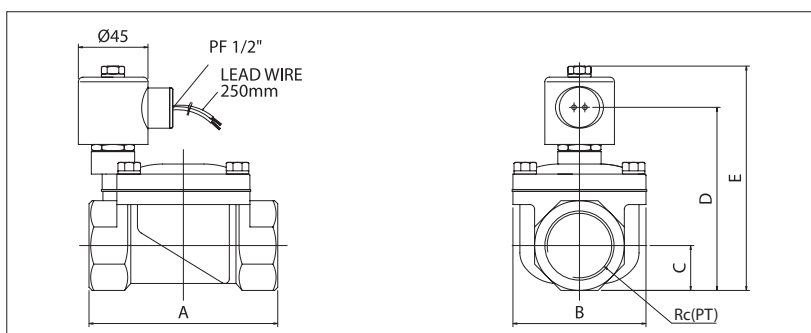

Model	A	B	C	D	E	Rc(PT)	Weight (kg)
HPW 3212	122	86	26	112	139	1 1/4	2.2
HPW 4014	122	86	29	118	145	1 1/2	2.47
HPW 5020	140	100	36	133	160	2	3.57

HPW6524 series

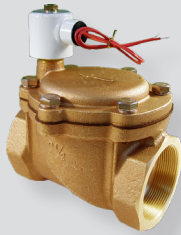

HPW 6524

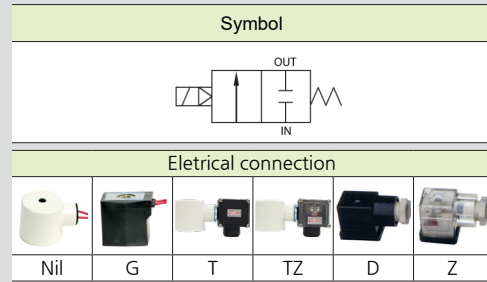

How to Order



① Port type

Nil	Rc(PT) (Standard)
G	G

② Orifice

65	Ø65
----	-----

③ Port size

24	2 1/2
----	-------

④ Electrical connection

Nil	Console box (Standard)
G	Grommet coil
T	Console box + Terminal box
TZ	Console box + Terminal box (Lamp)
D	DIN coil + DIN connector
Z	DIN coil + DIN connector (Lamp)

⑤ Seal material

	Material	Applications
Nil	NBR	Standard
M	FPM	Chemical, Hot water 120°C
E	EPDM	Hot water 100°C

⑥ Rated voltage

AC110V	AC110V 60Hz
AC220V	AC220V 60Hz
DC12V	DC12V
DC24V	DC24V
AC100V	AC100V 50/60Hz
AC200V	AC200V 50/60Hz
AC220V-50Hz	AC 220V 50Hz
AC240V-50Hz	AC 240V 50Hz
AC24V-50Hz	AC 24V 50Hz

Specifications

Classification	Standard	Option	Classification	Standard	Option
Fluid	Air, Water, Clean oil, Inert gas		Voltage	AC100V 50/60Hz AC110V 60Hz AC200V 50/60Hz AC220V 60Hz DC24V, 12V	AC110V 50Hz AC220V 50Hz AC240V 50Hz AC 24V 50Hz
Fluid temp.	0 ~ 60°C	EPDM FPM			
Ambient temp.	50°C (Max.)				
Pressure range	0.5 ~ 10kgf/cm ² (0.05 ~ 1MPa)		Allowable voltage fluctuation	±10% (AC), ±5% (DC)	
Coil insulation	Class B		Power consumption	AC, DC : 14W	
Electrical connection	Lead wire G(PF)1/2	Grommet coil Terminal box DIN connector	Body material	Bronze	
Port size	Rc(PT) 2 1/2		Seal material	PISTON NBR	EPDM, FPM
Orifice	Ø65		Weight	8.3kg	

* Not available in explosive atmosphere.

* If oil is applied, the range of pressure shall be based on 50cst for oil viscosity.

Features

- Piston pilot type
- Normally closed type
- Large capacity structure
- Fire resistant structure, high durability
- Seal material can be changed depending on fluid specifications.
- Diaphragm type

Applications

- Water piping
- Medical instrument
- Ventilator
- Air conditioner
- Boiler
- Blower
- Compressor
- High pressure washer

Dimensions

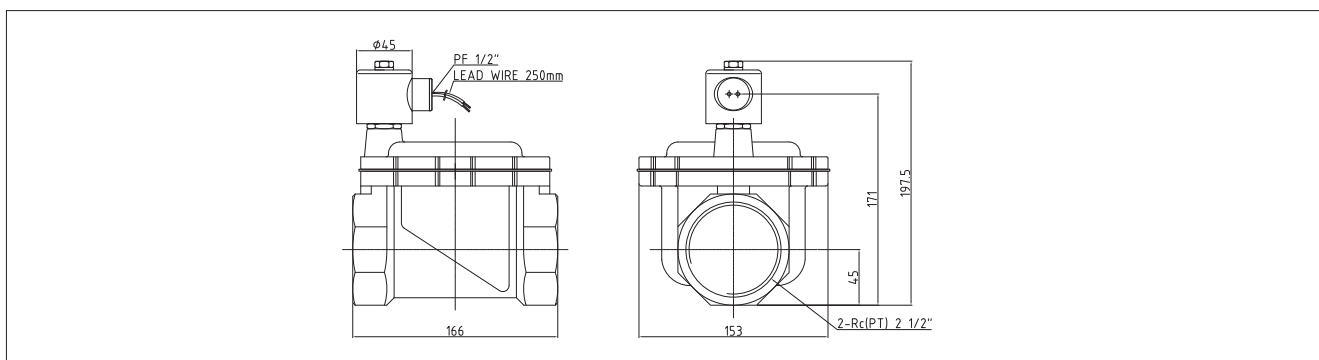

HPW8030 series



HPW 8030

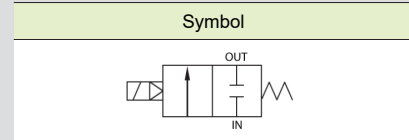

How to Order

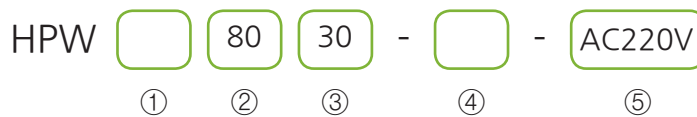

① Port size

Nil	Rc(PT) (Standard)
G	G

② Orifice

80	Ø80
----	-----

③ Port size

30	3
----	---

④ Seal material

	Material	Applications
Nil	NBR	(Standard)
M	FPM	Chemical, Hot water 120°C
E	EPDM	Hot water 100°C

⑤ Voltage

AC110V	AC110V 60Hz
AC220V	AC220V 60Hz
DC12V	DC12V
DC24V	DC24V
AC100V	AC100V 50/60Hz
AC200V	AC200V 50/60Hz
AC220V-50Hz	AC220V 50Hz
AC240V-50Hz	AC240V 50Hz
AC24V-50Hz	AC24V 50Hz

Specifications

Classification	Standard	Option	Classification	Standard	Option
Fluid	Air, Water, Clean oil, Inert gas		Voltage	AC100V 50/60Hz AC110V 60Hz AC200V 50/60Hz AC220V 60Hz DC24V, 12V	AC110V 50Hz AC220V 50Hz AC240V 50Hz AC 24V 50Hz
Fluid temp.	0 ~ 60°C	EPDM FPM			
Ambient temp.	50°C (Max.)				
Pressure range	1 ~ 10kgf/cm ² (0.05 ~ 1MPa)		Allowable voltage fluctuation	±10% (AC), ±5% (DC)	
Coil insulation	Class B		Power consumption	AC, DC : 30W	
Electrical connection	Terminal box Lead wire G(PF1/2)		Seal material	Bronze	
End connection	Rc(PT) 3		Seal Material	NBR	EPDM, FPM
Orifice	Ø80		Weight	15.2Kg	

Features

- Diaphragm type
- Normally closed type
- Seal material can be changed depending on fluid specifications.
- Fire resistant structure, Large capacity

Applications

- Water piping
- Ventilator
- Pressure washer
- Industrial washing machine
- Compressor
- Medical instrument
- Boiler
- Option : Blower machine

※ Not available in explosive atmosphere.

※ If oil is applied, the range of pressure shall be based on 50cst for oil viscosity.

Dimensions

