

Related Products: Auto Drain Valve AD402/600

Drainage is automatically discharged in a reliable manner, without requiring human operators.

Highly resistant to dust and corrosion, operates reliably, and a bowl guard is provided as standard equipment.



JIS Symbol



Model/Specifications

Model	AD402	AD600
Proof pressure	1.5 MPa	1.5 MPa
Max. operating pressure	1.0 MPa	1.0 MPa
Operating pressure range ^{Note)}	0.1 to 1.0 MPa	0.3 to 1.0 MPa
Ambient and fluid temperature	-5 to 60°C (No freezing)	-5 to 60°C (No freezing)
Port size	Rc 1/4, 3/8, 1/2	Rc 3/4, 1
Drain discharge port size	3/8	3/4, 1
Weight (g)	620	2100



Note) Use for air compressor with flow larger than 400 l/min (ANR).

Option Specifications

Metal bowl	AD402-□-2	—
------------	-----------	---

⚠ Precautions

Be sure to read before handling. Refer to pages 14-21-3 to 4 for Safety Instructions and Common Precautions on the products mentioned in this catalog, and refer to pages 14-14-6 to 8 for Precautions on every series.

Selection

⚠ Warning

- Use auto-drain under the following operating conditions, or it will lead to malfunctions.
 - Operate the compressor above 3.7 kw {400 l/min (ANR)}.
 - Use AD402 at an operating pressure above 0.1 MPa and AD600 above 0.3 MPa.

Piping

⚠ Warning

- Use auto-drain under the following operating conditions, or it will lead to malfunctions.

To connect a drain discharge pipe, use a pipe with a minimum bore of $\phi 10$, and a maximum length of 5 m. Avoid using a riser pipe.

Construction/Dimensions

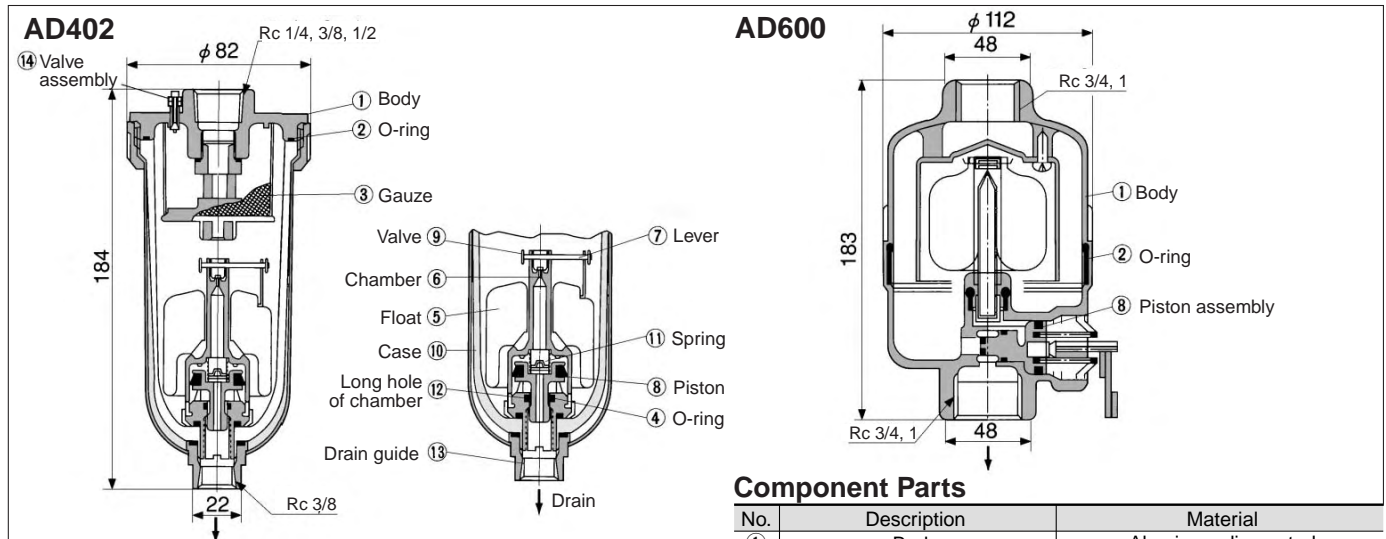

• Working principle (AD402)

- When no pressure is applied internally to bowl ⑩, float ⑤ descends of its own weight and valve ⑨ closes chamber hole ⑥. Piston ⑧ is pushed down by spring ⑪, and the drainage passes through the chamber's elongated hole ⑫ to enter the housing and is discharged.
- When pressure is applied internally to the bowl: When pressure is larger than 1 MPa, it overcomes the force of spring ⑪, allowing piston ⑧ to ascend, and comes in contact with O-ring ④. Thus, the inside of bowl ⑩ is isolated from the outside.
- When drainage has accumulated: Float ⑤ ascends due to flotation and opens the chamber's hole ⑥, allowing the pressure to enter chamber ⑥. Piston ⑧ descends due to the force of the internal pressure and spring ⑪, and the accumulated drainage is discharged through drain guide ⑬.

Component Parts

No.	Description	Material
①	Body	Aluminum die-casted

Replacement Parts

No.	Description	Material	Model	
			AD402	AD600
②	O-ring	NBR	113136	JIS B 2401G-100
③	Gauze	Stainless steel	20062	—
(1)	Internal assembly	—	AD34PA	—
⑧	Piston assembly	—	—	20025A
⑭	Valve assembly	—	201037P	—

Note 1) Internal assembly: Assembly for parts ④ to ⑫ except ⑩.

Note 2) Part no. for bowl assembly: AD34

Note 3) Part no. for bowl ⑩: 201016

HA □

AT

ID □

AMG

AFF

AM □

Misc.

AUTO DRAIN SERIES (N)AD

- ✓ Port Sizes 1/4~1
- ✓ Float Type Automatic Drain Valve



TECHNICAL SPECIFICATIONS

Type	(N)AD402	(N)AD600
Operating Pressure	1.5~9.9 Bar 22~145PSI	3~9.9 Bar 45~145PSI
Max Supply Pressure	15 Bar / 220PSI	
Max Operating Pressure	9.9 Bar / 145PSI	
Ambient & Fluid Temperature	5 ~ 60°C / 40~140°F	
Port Size	1/2	3/4, 1
Drain Port	3/4	3/4, 1

DIMENSIONS

AD SERIES AUTO DRAINS

AD402

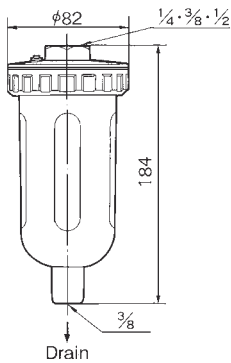

AD600

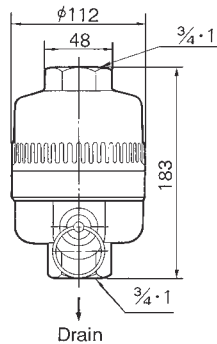

SYMBOLS



HOW TO ORDER

AUTODRAIN SERIES AD

- AD402-02 (1/4) PT
- AD402-03 (3/8) PT
- AD402-04 (1/2) PT
- AD600-06 (3/4) PT
- AD600-10 (1) PT

FOR FURTHER TECHNICAL DETAILS ON THIS PRODUCT CONSULT SMC CUSTOMER SERVICE

HOW TO ORDER

AUTODRAIN SERIES NAD

- NAD402-N02 (1/4) NPT
- NAD402-N03 (3/8) NPT
- NAD402-N04 (1/2) NPT
- NAD600-N06 (3/4) NPT
- NAD600-N10 (1) NPT



FOR FURTHER TECHNICAL DETAILS ON THIS PRODUCT CONSULT SMC CUSTOMER SERVICE

DIMENSIONS

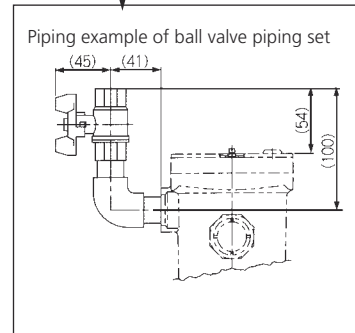
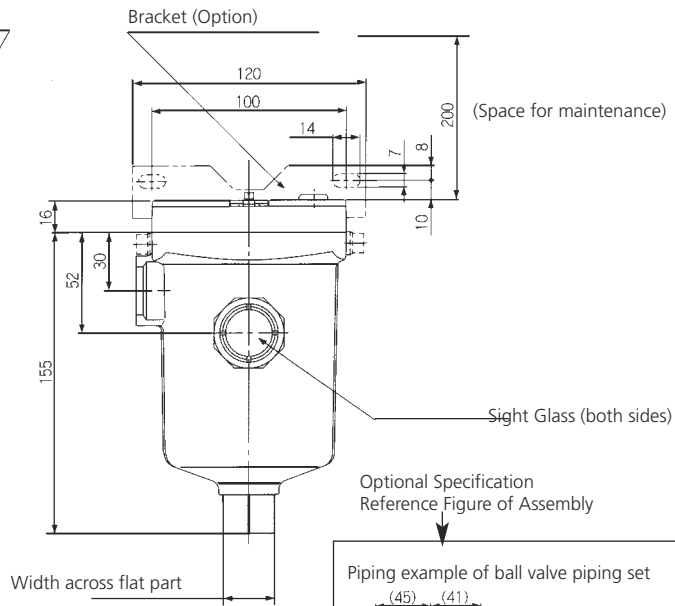
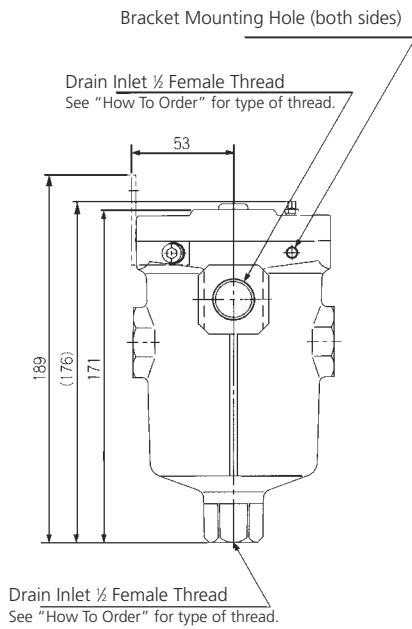
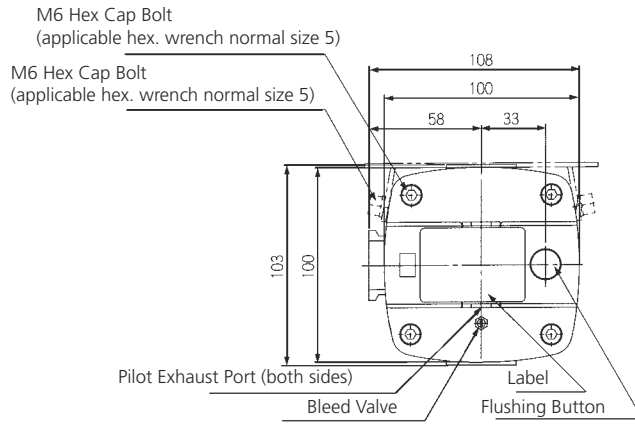





Safety Instructions

These safety instructions are intended to prevent a hazardous situation and/or equipment damage. These instructions indicate the level of potential hazard by labels of "Caution", "Warning" or "Danger". To ensure safety, be sure to observe ISO 4414 ^{Note 1)}, JIS B 8370 ^{Note 2)} and other safety practices.

 **Caution** : Operator error could result in injury or equipment damage.

 **Warning** : Operator error could result in serious injury or loss of life.

 **Danger** : In extreme conditions, there is a possible result of serious injury or loss of life.

Note 1) ISO 4414: Pneumatic fluid power--General rules relating to systems.

Note 2) JIS B 8370: General Rules for Pneumatic Equipment

Warning

1. The compatibility of pneumatic equipment is the responsibility of the person who designs the pneumatic system or decides its specifications.

Since the products specified here are used in various operating conditions, their compatibility for the specific pneumatic system must be based on specifications or after analysis and/or tests to meet your specific requirements. The expected performance and safety assurance will be the responsibility of the person who has determined the compatibility of the system. This person should continuously review the suitability of all items specified, referring to the latest catalog information with a view to giving due consideration to any possibility of equipment failure when configuring a system.

2. Only trained personnel should operate pneumatically operated machinery and equipment.

Compressed air can be dangerous if an operator is unfamiliar with it. Assembly, handling or repair of pneumatic systems should be performed by trained and experienced operators.

3. Do not service machinery/equipment or attempt to remove components until safety is confirmed.

1. Inspection and maintenance of machinery/equipment should only be performed once measures to prevent falling or runaway of the driver objects have been confirmed.
2. When equipment is to be removed, confirm the safety process as mentioned above. Cut the supply pressure for this equipment and exhaust all residual compressed air in the system.
3. Before machinery/equipment is restarted, take measures to prevent shooting-out of cylinder piston rod, etc.

4. Contact SMC if the product is to be used in any of the following conditions:

1. Conditions and environments beyond the given specifications, or if product is used outdoors.
2. Installation on equipment in conjunction with atomic energy, railway, air navigation, vehicles, medical equipment, food and beverages, recreation equipment, emergency stop circuits, clutch and brake circuits in press applications, or safety equipment.
3. An application which has the possibility of having negative effects on people, property, or animals, requiring special safety analysis.



Common Precautions

Be sure to read before handling.

For detailed precautions on every series, refer to main text.

Selection

Warning

1. Confirm the specifications.

Products represented in this catalog are designed for use in compressed air applications only (including vacuum), unless otherwise indicated.

Do not use the product outside their design parameters.

Please contact SMC when using the products in applications other than compressed air (including vacuum).

Mounting

Warning

1. Instruction manual

Install the products and operate them only after reading the instruction manual carefully and understanding its contents. Also keep the manual where it can be referred to as necessary.

2. Securing the space for maintenance

When installing the products, please allow access for maintenance.

3. Tightening torque

When installing the products, please follow the listed torque specifications.

Piping

Caution

1. Before piping

Make sure that all debris, cutting oil, dust, etc., are removed from the piping.

2. Wrapping of pipe tape

When screwing piping or fittings into ports, ensure that chips from the pipe threads or sealing material do not get inside the piping. Also, when the pipe tape is used, leave 1.5 to 2 thread ridges exposed at the end of the threads.

Air Supply

Warning

1. Operating fluid

Please consult with SMC when using the product in applications other than compressed air (including vacuum).

Regarding products for general fluid, please ask SMC about applicable fluids.

2. Install an air dryer, aftercooler, etc.

Excessive condensate in a compressed air system may cause valves and other pneumatic equipment to malfunction.

Installation of an air dryer, after cooler etc. is recommended.

3. Drain flushing

If condensate in the drain bowl is not emptied on a regular basis, the bowl will over flow and allow the condensate to enter the compressed air lines.

If the drain bowl is difficult to check and remove, it is recommended that a drain bowl with the auto-drain option be installed.

For compressed air quality, refer to "Air Preparation Equipment" catalog.

4. Use clean air

If the compressed air supply is contaminated with chemicals, synthetic materials, corrosive gas, etc., it may lead to break down or malfunction.

Operating Environment

Warning

1. Do not use in environments where the product is directly exposed to corrosive gases, chemicals, salt water, water or steam.

2. Do not expose the product to direct sunlight for an extended period of time.

3. Do not use in a place subject to heavy vibrations and/or shocks.

4. Do not mount the product in locations where it is exposed to radiant heat.

Maintenance

Warning

1. Maintenance procedures are outlined in the operation manual.

Not following proper procedures could cause the product to malfunction and could lead to damage to the equipment or machine.

2. Maintenance work

If handled improperly, compressed air can be dangerous.

Assembly, handling and repair of pneumatic systems should be performed by qualified personnel only.

3. Drain flushing

Remove drainage from air filters regularly. (Refer to the specifications.)

4. Shut-down before maintenance

Before attempting any kind of maintenance make sure the supply pressure is shut of and all residual air pressure is released from the system to be worked on.

5. Start-up after maintenance and inspection

Apply operating pressure and power to the equipment and check for proper operation and possible air leaks. If operation is abnormal, please verify product set-up parameters.

6. Do not make any modifications to be product.

Do not take the product apart.